

General Description

The TD1722 is a voltage mode, fixed 200kHz/300kHz/600kHz switching frequency, synchronous buck converter. The APW8722 allows wide input voltage that is either a single 5~12V or two supply voltage(s) for various applications. A power-on-reset (POR) circuit monitors the VCC supply voltage to prevent wrong logic controls.

A built-in soft-start circuit prevents the output voltages from over-shoot as well as limits the input current. An internal 0.6V/0.8V Temperature-compensated reference voltage with high accuracy is designed to meet the requirement of low output voltage applications. The APW8722 provides excellent output voltage regulations against load current variation. The controller's over-current protection monitors the output current by using the voltage drop across the $R_{DS(ON)}$ of low-side MOSFET, eliminating the need for a current sensing resistor that features high efficiency and low cost. In addition, the TD1722 also integrates excellent protection functions. The over-voltage protection (OVP), under-voltage protection (UVP). OVP circuit which monitors the FB voltage to prevent the PWM output from over voltage, and UVP circuit which monitors the FB voltage to prevent the PWM output from under voltage or short circuit. The TD1722 is available in SOP-8P packages

Features

- Wide 5V to 12V Supply Voltage
- Power-On-Reset Monitoring on VCC
- Excellent Output Voltage Regulations
- 0.6V Internal Reference for TD1722/A/D
- 0.8V Internal Reference for TD1722B/C
- $\pm 0.6\%$ Over-Temperature Range
- Integrated Soft-Start
- Voltage Mode PWM Operation with External Compensation
- Up to 90%DutyRatio for Fast Transient Response
- Constant Switching Frequency
- 300kHz $\pm 10\%$ for TD1722/B
- 200kHz $\pm 10\%$ for TD1722C
- 600kHz $\pm 10\%$ for TD1722A/D
- Integrated Bootstrap Forward P-CH MOSFET
- 50%Under-Voltage Protection
- 125%Over-Voltage Protection
- Adjustable Over-Current Protection Threshold
- Using the $R_{DS(ON)}$ of Low-Side MOSFET
- Shutdown Control byCOMP
- SOP-8P Package
- Lead Free and Green Devices Available

Applications

- Graphic Cards
- DSL, Switch HUB
- Wireless Lan
- Notebook Computer
- Mother Board
- LCD Monitor/TV

Pin Description

No.		Name	
TD1722A	TD1722/B/C/D		
1	1	BOOT	This pin provides the bootstrap voltage to the high-side gate driver for driving the N-channel MOSFET. An external capacitor from PHASE to BOOT, an internal switch generates
2	2	UGATE	High-side Gate Driver Output. This pin is the gate driver for high-side
-	3	GND	Signal and Power ground. Connecting this pin to system ground.
3	-	OCSET	Current-Limit Threshold Setting Pin. There is an internal source current 10uA through a resistor from OCSET pin to GND. This pin is used to monitor the voltage drop across the Drain and
4	-	LGATE	Output of The Low-side MOSFET Driver. Connect this pin to the low-side MOSFET.
-	4	LGATE/ OCSET	Low-side Gate Driver Output and Over-Current Setting Input. This pin is the gate driver for low-side MOSFET. It also used to set the maximum inductor current. Refer to the section in “Function Description” for detail.
5	5	VCC	Power Supply Input. Connect a nominal 5V to 12V power supply voltage to this pin. A power-on reset function monitors the input voltage at this pin. It is recommended that a decoupling capacitor (1 to 10µF) be connected to GND for noise decoupling.
6	6	FB	Feedback Input of Converter. The converter senses feedback voltage via FB and regulates the FB voltage at 0.6V/0.8V. Connecting FB with a resistor-divider from the output sets the output voltage of the converter.
7	7	COMP	This is a multiplexed pin. During soft-start and normal converter operation, this pin represents the output of the error amplifier. It is used to compensate the regulation control loop in combination with the FB pin. Pulling COMP low ($V_{\text{DISABLE}} = 0.4\text{V max.}$) will shut down the controller. When the pull-down device is released, the COMP pin will start to rise. When the COMP pin rises above the V_{DISABLE} trip point, the TD1722 will begin a new initialization and soft-start cycle.

Single Buck Voltage Mode PWM Controller

TD1722

8	8	PHASE	This pin is the return path for the high-side gate driver. Connecting this pin to the high-side MOSFET source and connect a capacitor to BOOT for the bootstrap voltage. This pin is also used
9 (Exposed Pad)	9 (Exposed Pad)	GND	Thermal Pad. Connect this pad to the system ground plan for good thermal conductivity.

Pin Assignments

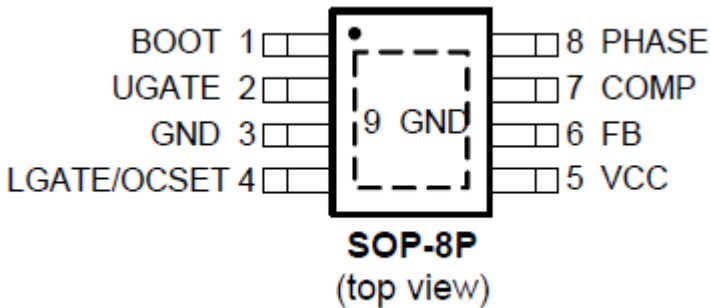

Ordering Information

TD1722 □ □ □

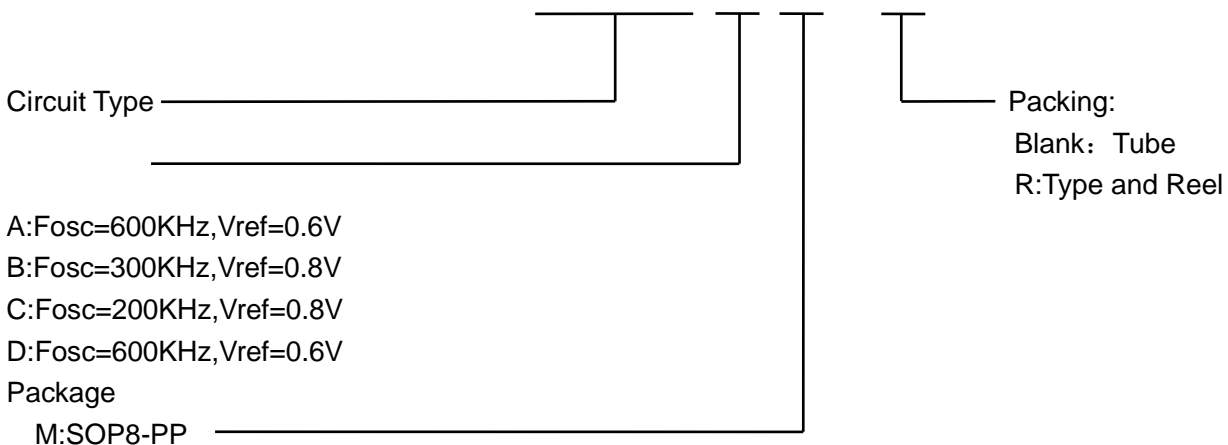

Functional Block Diagram

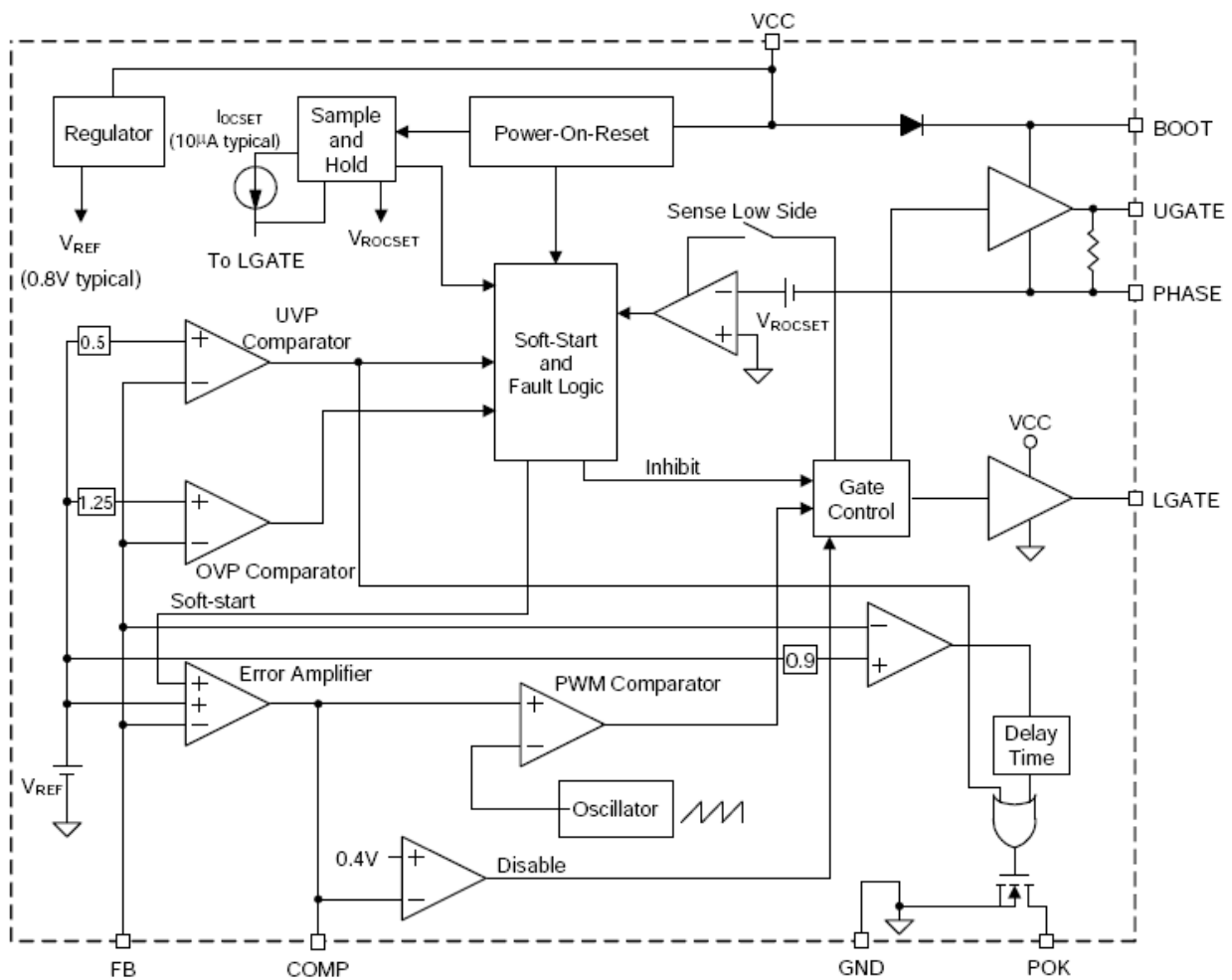

Functional Block Diagram of TD1722

Absolute Maximum Ratings

Symbol	Parameter	Rating	Unit	
V _{VCC}	VCC Supply Voltage (VCC to GND)	-0.3 ~ 16	V	
V _{BOOT}	BOOT Supply Voltage (BOOT to PHASE)	-0.3 ~ 16	V	
	BOOT Supply Voltage (BOOT to GND)	-0.3 ~ 30	V	
V _{UGATE}	UGATE Voltage (UGATE to PHASE)	> 20ns	-0.3 ~ V _{BOOT} +0.3	V
		< 20ns	-5 ~ V _{BOOT} +5	V
V _{LGATE}	LGATE Voltage (LGATE to GND)	> 20ns	-0.3 ~ V _{VCC} +0.3	V
		< 20ns	-5 ~ V _{VCC} +5	V
V _{PHASE}	PHASE Voltage (PHASE to GND)	> 20ns	-0.3 ~ 16	V
		< 20ns	-8 ~ 30	V
	FB and COMP to GND	-0.3 ~ 7	V	
	POK to GND	-0.3~V _{CC} +0.3	V	
T _J	Maximum Junction Temperature	150	°C	
T _{STG}	Storage Temperature	-65 ~ 150	°C	
T _{SDR}	Maximum Lead Soldering Temperature, 10 Seconds	260	°C	

Note: Stresses beyond those listed under "absolute maximum ratings" may cause permanent damage to the device. These are stress ratings only and functional operation of the device at these or any other conditions beyond those indicated under "recommended operating conditions" is not implied. Exposure to absolute maximum rating conditions for extended periods may affect device reliability.

Recommended Operating Conditions

Symbol	Parameter	Range	Unit
V _{IN}	V _{IN} Supply Voltage	3.3 ~ 13.2	V
V _{VCC}	VCC Supply Voltage	4.5 ~ 13.2	V
V _{OUT}	Converter Output Voltage	0.8 ~ 5.5	V
I _{OUT}	Converter Output Current	0 ~ 20	A
T _A	Ambient Temperature	-40 ~ 85	°C
T _J	Junction Temperature	-40 ~ 125	°C

Note : Refer to the application circuit for further information.

Thermal Characteristics

Symbol	Parameter	Typical Value	Unit
JA	Thermal Resistance -Junction to Ambient ^(Note 2) SOP-8P	60	°C/W

Note :is measured with the component mounted on a high effective thermal conductivity test board in free air.

Electrical Characteristics

Refer to the typical application circuit. These specifications apply over $V_{VCC} = 12V$, $T_A = -40^{\circ}C$ to $85^{\circ}C$, unless otherwise noted. Typical values are at $T_A = 25^{\circ}C$.

Symbol	Parameter	Test Conditions	TD1722			Unit
			Min.	Typ.	Max.	
INPUT SUPPLY VOLTAGE AND CURRENT						
IVCC	VCC Supply Current (Shutdown Mode)	UGATE and LGATE open; COMP=GND	-	-	550	uA
	VCC Supply Current	UGATE and LGATE open	-	2.5	10	mA
POWER-ON-RESET(POR)						
	Rising VCC POR Threshold		3.8	4.1	4.4	V
	VCC POR Hysteresis		0.3	0.5	0.6	V
OSCILLATOR						
FOSC	Oscillator Frequency	For TD1722B	270	300	330	kHz
		For TD1722C	180	200	220	
		For TD1722A/D	540	600	660	
VOSC	(Note 4)	(1.2V~2.7V typical)	-	1.5	-	V
DMAX	Maximum Duty Cycle		-	-	90	%
REFERENCE						
VREF	Reference Voltage	$T_A = -40 \sim 85^{\circ}C$ TD1722B/C	0.792	0.8	0.808	V
		$T_A = -40 \sim 85^{\circ}C$ TD1722A/D	0.596	0.6	0.604	
	Converter Line/Load Regulation	$V_{CC}=4.5\sim 13.2V, I_{OUT} = 0 \sim$	-0.2	-	0.2	%
ERROR AMPLIFIER						
	Open-Loop Bandwidth (Note)	$R_L = 10k, C_L = 10pF$	-	20	-	MHz
	FB Input Leakage Current	$V_{FB} = 0.8V$	-	-	0.1	uA

Electrical Characteristics(Cont.)

Refer to the typical application circuit. These specifications apply over $V_{VCC} = 12V$, $T_A = -40^{\circ}C$ to $85^{\circ}C$, unless otherwise noted. Typical values are at $T_A = 25^{\circ}C$.

Symbol	Parameter	Test Conditions	TD1722			Unit
			Min.	Typ.	Max.	
GATE DRIVERS						
	High-Side Gate Driver Source	$V_{BOOT-GND} = 12V, V_{UGATE-PHASE} = 6V$	-	1.0	-	
	High-Side Gate Driver Sink Current	$V_{BOOT-GND} = 12V, V_{UGATE-PHASE} = 6V$	-	1.5	-	A
	Low-Side Gate Driver Source	$V_{VCC} = 12V, V_{LGATE-GND} = 6V$	-	1.8	-	
	Low-Side Gate Driver Sink Current	$V_{VCC} = 12V, V_{LGATE-GND} = 6V$	-	2.0	-	A
T_D	Dead-Time ^(Note 4)		-	30	-	ns
PROTECTIONS						
V_{FB_UV}	FB Under-Voltage Protection Trip	Percentage of V_{REF}	40	45	50	%
	Under-Voltage Debounce Interval		-	2	-	s
	Under-Voltage Protection Enable Delay	The same as soft -start interval	1	1.5	2	ms
V_{FB_OV}	FB Over-Voltage Protection Trip	V_{FB} rising	115	125	135	%
	FB Over-Voltage Protection		-	5	-	%
	Over-Voltage Debounce Interval		-	2	-	s
V_{OCP_MAX}	Built-in Maximum OCP Voltage		350	-	-	mV
I_{OCSET}	OCSET Current Source		9	10	11	uA
SOFT-START						
$V_{DISABLE}$	Shutdown Threshold of V_{COMP}		-	-	0.4	V
T_{SS}	Internal Soft-Start Interval ^(Note 4)		1	1.5	2	ms

Typical Operating Characteristics

Reference Voltage vs. Junction Temperature

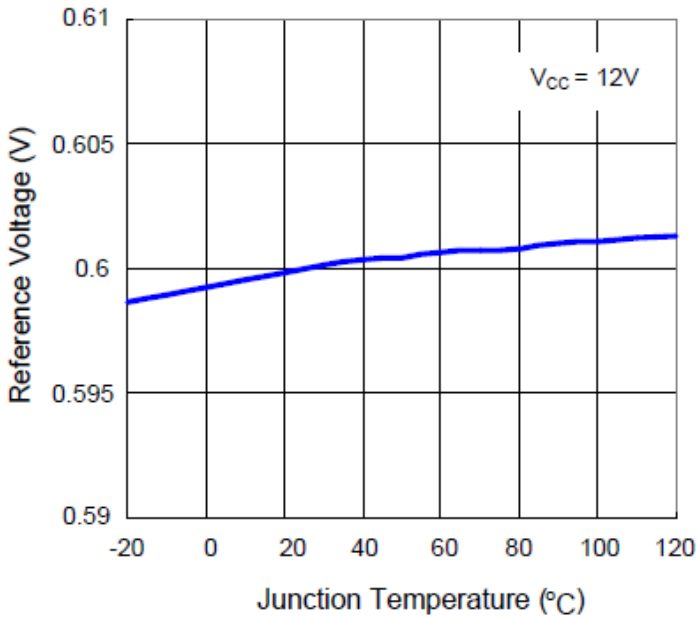

Efficiency vs. Load Current
F_{SW}=300KHz, V_{OUT}=1.2V

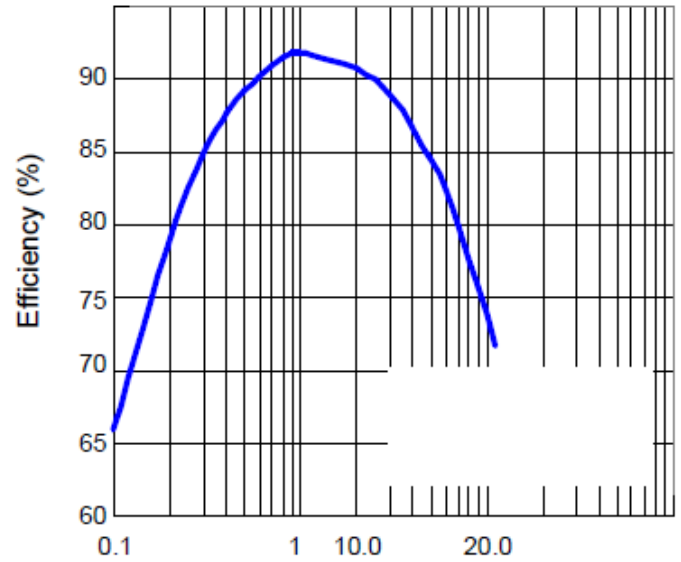

Switching Frequency vs. Junction Temperature

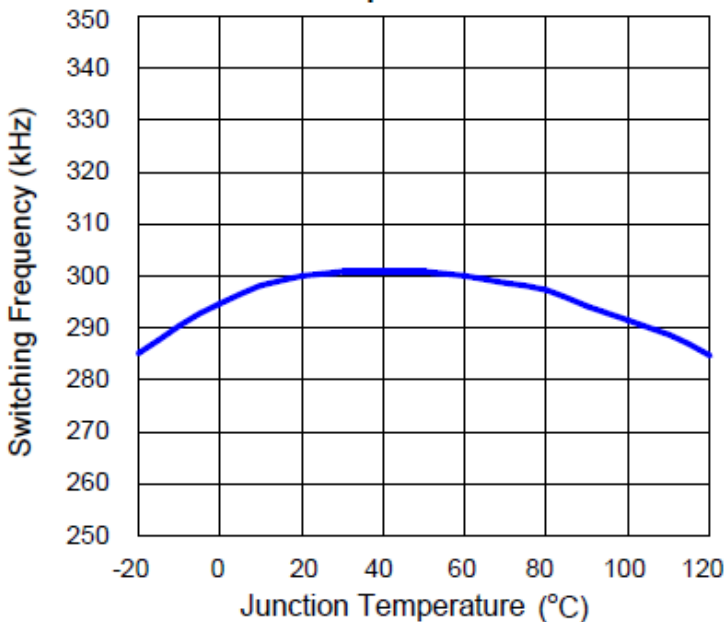

Switching Frequency vs. Junction Temperature

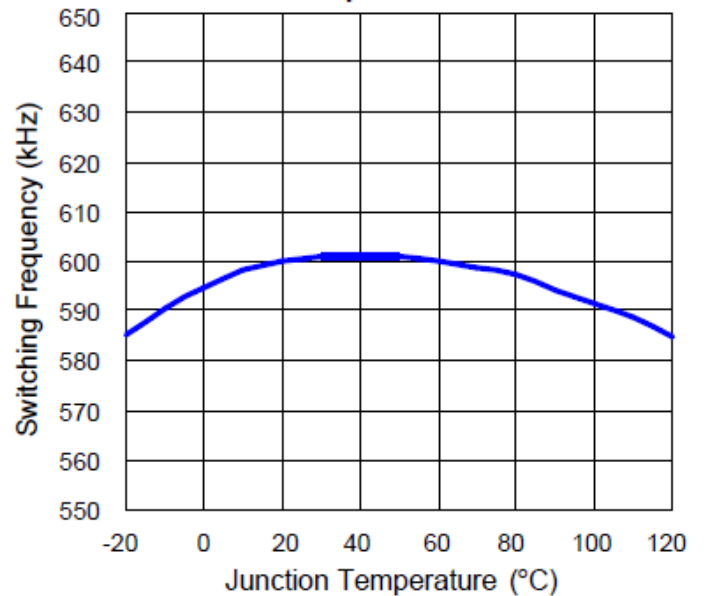

Typical Operating Characteristics(Cont.)

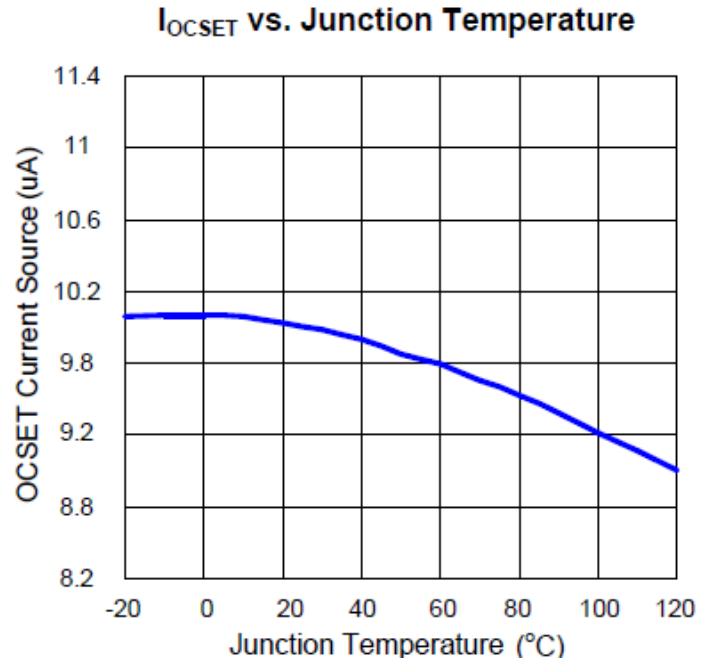
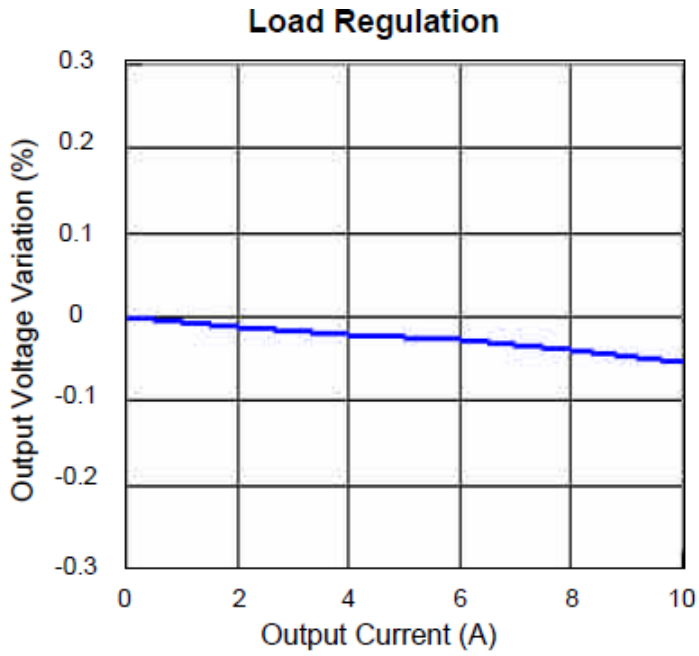

Typical Application Circuit

TD1722 B/C/D Application Circuit

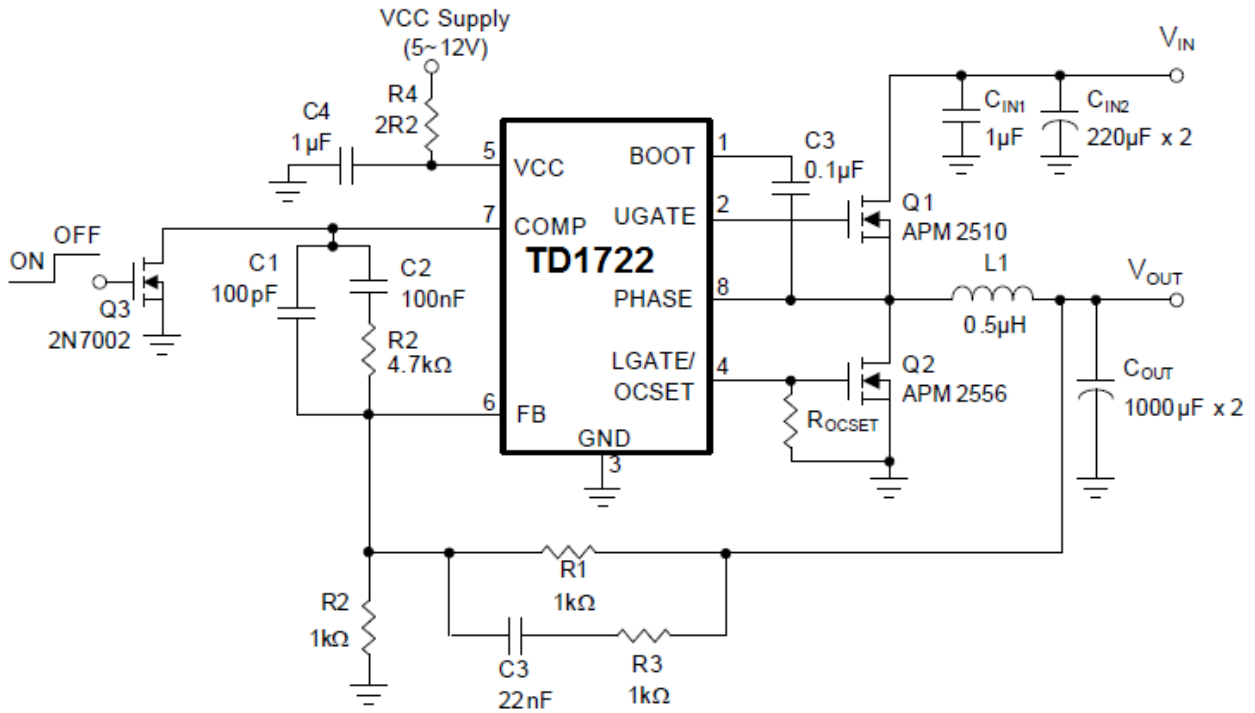

TD1722A Application Circuit

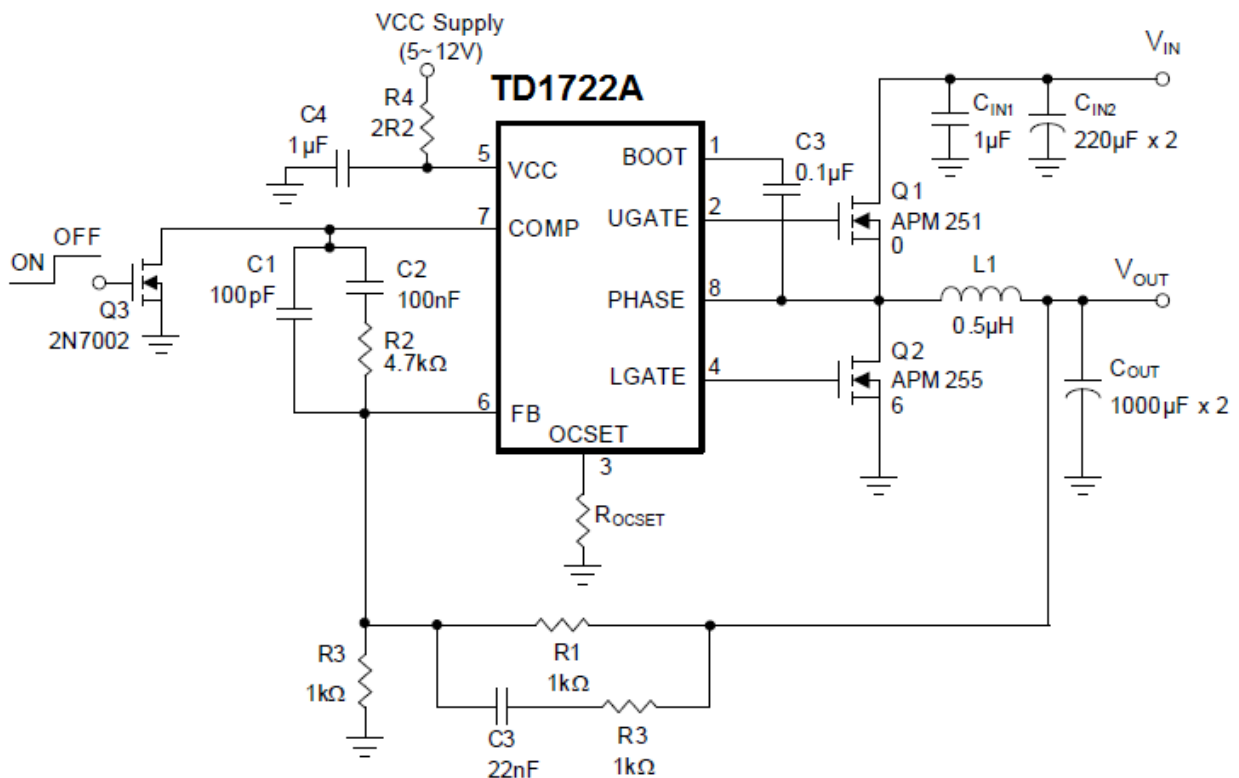

Function Description

Power-On-Reset (POR)

The Power-On-Reset (POR) function of TD1722 continually monitors the input supply voltage (VCC) and ensures that the IC has sufficient supply voltage and can work well. The POR function initiates a soft-start process while the VCC voltage just exceeds the POR threshold; the POR function also inhibits the operations of the IC while the VCC voltage falls below the POR threshold.

Soft-Start

The TD1722 builds in a soft-start function about 1.5ms (Typ.) interval, which controls the output voltage rising as well as limiting the current surge at the start-up. During soft-start, an internal ramp voltage connected to the one of the positive inputs of the error amplifier replaces the reference voltage (0.8V typical) until the ramp voltage reaches the reference voltage. The soft-start circuit interval is shown as figure 1. The UVP function enable delay is from t2 to t3.

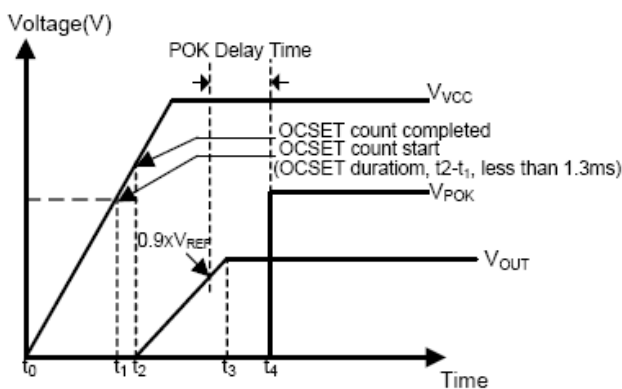

Over-Current Protection of the PWM Converter

The over-current function protects the switching converter against over-current or short-circuit conditions. The controller senses the inductor current by detecting the drain-to-source voltage which is the product of the inductor's current and the on-resistance of the low-side MOSFET during its on-state. This method enhances the converter's efficiency and reduces cost by eliminating a current sensing resistor required.

A resistor (R_{OCSET}), connected from the LGATE/OCSET to GND, programs the over-current trip level. Before the IC initiates a soft-start process, an internal current source, I_{OCSET} (10μA typical), flowing through the R_{OCSET} develops a voltage (V_{ROCSET}) across the R_{OCSET}. The device holds V_{ROCSET} and stops the current source I_{OCSET} during normal operation. When the voltage across the low-side MOSFET exceeds the V_{ROCSET}, the TD1722 turns off the highside and low-side MOSFET, and the device will enter hiccup mode until the over-current phenomenon is released.

The TD1722 has an internal OCP voltage, V_{OCP_MAX}, and the value is 0.35V (minimum). When the R_{OCSET} × I_{OCSET} exceeds 0.35V or the R_{OCSET} is floating or not connected, the V_{ROCSET} will be the default value 0.35V. The over current threshold would be 0.35V across low-side MOSFET. The threshold of the valley inductor current-limit is therefore given by:

$$I_{LIMIT} = \frac{I_{OCSET} \times R_{OCSET}}{R_{DS(ON)}(low - side)}$$

For the over-current is never occurred in the normal operating load range, the variation of all parameters in the above equation should be considered:

- The R_{DS(ON)} of low-side MOSFET is varied by temperature and gate to source voltage. Users should determine the maximum R_{DS(ON)} by using the manufacturer's datasheet.
- The minimum I_{OCSET} (9μA) and minimum R_{OCSET} should be used in the above equation.
- Note that the I_{LIMIT} is the current flow through the lowside MOSFET; I_{LIMIT} must be greater than valley inductor current which is output current minus the half of inductor ripple current.

$$I_{LIMIT} > I_{OUT(MAX)} - \frac{\Delta I}{2}$$

Where ΔI = output inductor ripple current

- The overshoot and transient peak current also should be considered.

Function Description(Cont.)

Under-Voltage Protection

The under-voltage function monitors the voltage on FB (V_{FB}) by Under-Voltage (UV) comparator to protect the PWM converter against short-circuit conditions. When the V_{FB} falls below the falling UVP threshold ($50\% V_{REF}$), a fault signal is internally generated and the device turns off highside and low-side MOSFETs. The device will enters hiccup mode until the under-voltage phenomenon is released.

Over-Voltage Protection (OVP) of the PWM Converter

The over-voltage protection monitors the FB voltage to prevent the output from over-voltage condition. When the output voltage rises above 125% of the nominal output voltage, the TD1722 turns off the high-side MOSFET and turns on the low-side MOSFET until the output voltage falls below the falling OVP threshold.

Shutdown and Enable

The TD1722 can be shut down or enabled by pulling low the voltage on COMP. The COMP is a dual-function pin. During normal operation, this pin represents the output of the error amplifier. It is used to compensate the regulation control loop in combination with the FB pin. Pulling the COMP low ($V_{DISABLE} = 0.4V$ maximum) places the controller into shutdown mode which UGATE and LGATE are pulled to PHASE and GND respectively. When the pull-down device is released, the COMP voltage will start to rise. When the COMP voltage rises above the $V_{DISABLE}$ threshold, the TD1722 will begin a new initialization and soft-start process.

Adaptive Shoot-Through Protection of the PWM Converter

The gate drivers incorporate an adaptive shoot-through protection to prevent high-side and low-side MOSFETs from conducting simultaneously and shorting the input supply. This is accomplished by ensuring the falling gate has turned off one MOSFET before the other is allowed to rise.

During turn-off the low-side MOSFET, the LGATE voltage is monitored until it is below 1.5V threshold, at which time the UGATE is released to rise after a constant delay. During turn-off of the high-side MOSFET, the UGATE-to-PHASE voltage is also monitored until it is below 1.5V threshold, at which time the LGATE is released to rise after a constant delay.

Power OK Indicator

The TD1722 features an open-drain POK output pin to indicate one of the IC's working statuses including soft-start, under-voltage fault, over-current fault. In normal operation, when the output voltage rises 90% of its target value, the POK goes high. When the output voltage outruns 50% or 125% of the target voltage, POK signal will be pulled low immediately.

Application Information

Output Voltage Selection

The output voltage can be programmed with a resistive divider.

Use 1% or better resistors for the resistive divider is recommended. The FB pin is the inverter input of the error amplifier, and the reference voltage is 0.8V/0.6V. The output voltage is determined by:

$$V_{OUT} = 0.8/0.6 \times \left(1 + \frac{R_1}{R_2}\right)$$

Where R1 is the resistor connected from V_{OUT} to FB and R2 is the resistor connected from FB to the GND.

Output Capacitor Selection

The selection of C_{OUT} is determined by the required effective series resistance (ESR) and voltage rating rather than the actual capacitance requirement. Therefore, selecting high performance low ESR capacitors is intended for switching regulator applications. In some applications, multiple capacitors have to be paralleled to achieve the desired ESR value. If tantalum capacitors are used, make sure they are surge tested by the manufactures. If in doubt, consult the capacitors manufacturer.

Input Capacitor Selection

The input capacitor is chosen based on the voltage rating and the RMS current rating. For reliable operation, select the capacitor voltage rating to be at least 1.3 times higher than the maximum input voltage. The maximum RMS current rating requirement is approximately I_{OUT}/2 where I_{OUT} is the load current. During power up, the input capacitors have to handle large amount of surge current. If tantalum capacitors are used, make sure they are surge tested by the manufactures. If in doubt, consult the capacitors manufacturer. For high frequency decoupling, a ceramic capacitor between 0.1μF to 1μF can connect between VCC and ground pin.

Inductor Selection

The inductance of the inductor is determined by the output voltage requirement. The larger the inductance, the lower the inductor's current ripple. This will translate into lower output ripple voltage. The ripple current and ripple voltage can be approximated by:

$$I_{RIPPLE} = \frac{V_{IN} - V_{OUT}}{F_{SW} \times L} \times \frac{V_{OUT}}{V_{IN}}$$

where F_s is the switching frequency of the regulator.

$$\Delta V_{OUT} = I_{RIPPLE} \times ESR$$

A tradeoff exists between the inductor's ripple current and the regulator load transient response time. A smaller inductor will give the regulator a faster load transient response at the expense of higher ripple current and vice versa. The maximum ripple current occurs at the maximum input voltage. A good starting point is to choose the ripple current to be approximately 30% of the maximum output current.

Once the inductance value has been chosen, selecting an inductor is capable of carrying the required peak current without going into saturation. In some types of inductors, especially core that is made of ferrite, the ripple current will increase abruptly when it saturates. This will result in a larger output ripple voltage.

Compensation

The output LC filter of a step down converter introduces a double pole, which contributes with -40dB/decade gain slope and 180 degrees phase shift in the control loop. A compensation network between COMP pin and ground should be added. The simplest loop compensation network is shown in Figure 5. The output LC filter consists of the output inductor and output capacitors. The transfer function of the LC filter is given by:

$$GAIN_{LC} = \frac{1 + s \times ESR \times C_{OUT}}{s^2 \times L \times C_{OUT} + s \times ESR \times C_{OUT} + 1}$$

The poles and zero of this transfer function are:

$$F_{LC} = \frac{1}{2 \times \pi \times \sqrt{L \times C_{OUT}}}$$

$$F_{ESR} = \frac{1}{2 \times \pi \times ESR \times C_{OUT}}$$

The FLC is the double poles of the LC filter, and FESR is the zero introduced by the ESR of the output capacitor.

Application Information(Cont.)

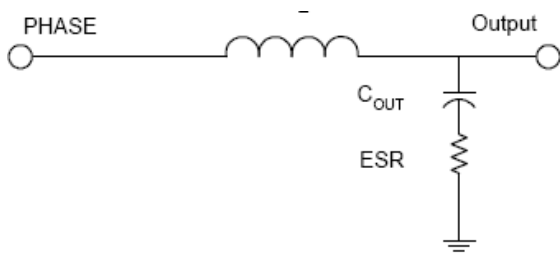

Figure 2. The Output LC Filter

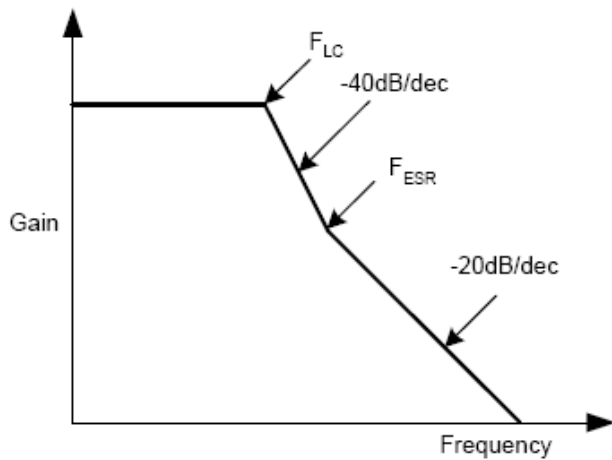

Figure 3. The LC Filter Gain & Frequency

The PWM modulator is shown in Figure 4. The input is the output of the error amplifier and the output is the PHASE node. The transfer function of the PWM modulator is given by:

$$GAIN_{PWM} = \frac{V_{IN}}{\Delta V_{OSC}}$$

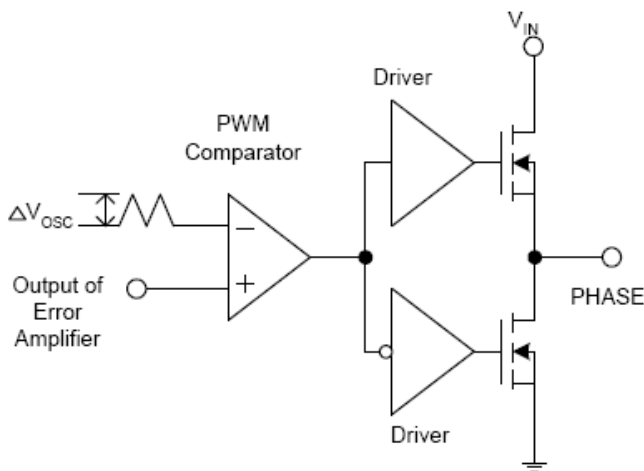

Figure 4. The PWM Modulator

The compensation circuit is shown in Figure 5. R2 and C2 introduce a zero and C1 introduces a pole to reduce the switching noise. The transfer function of error amplifier is given by:

$$GAIN_{AMP} = gm \times Z_O = gm \times \left[\left(R2 + \frac{1}{sC2} \right) // \frac{1}{sC1} \right]$$

$$= gm \times \frac{\left(s + \frac{1}{R2 \times C2} \right)}{s \times \left(s + \frac{C2 + C1}{R2 \times C1 \times C2} \right) \times C1}$$

The pole and zero of the compensation network are:

$$F_P = \frac{1}{2 \times \pi \times R2 \times \frac{C1 \times C2}{C1 + C2}}$$

$$F_Z = \frac{1}{2 \times \pi \times R2 \times C2}$$

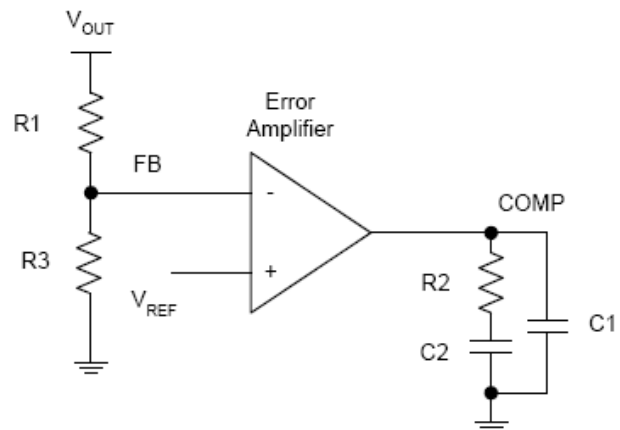

Figure 5. Compensation Network

The closed loop gain of the converter can be written as:

$$GAIN_{LC} \times GAIN_{PWM} \times \frac{R3}{R1 + R3} \times GAIN_{AMP}$$

Figure 6 shows the converter gain and the following guidelines will help to design the compensation network.

1. Select the desired zero crossover frequency F_o :

$$\left(\frac{1}{5} \sim \frac{1}{10} \right) \times F_{sw} > F_o > F_z$$

Use the following equation to calculate R2:

$$R2 = \frac{\Delta V_{OSC}}{V_{IN}} \times \frac{F_{ESR}}{F_{LC}^2} \times \frac{R1 + R3}{R3} \times \frac{F_o}{gm}$$

Where: $gm = 667 \mu A/V$

Application Information(Cont.)

2. Place the zero F_z before the LC filter double poles F_{LC} :

$$F_z = 0.75 \times F_{LC}$$

Calculate the C_2 by the equation:

$$C_2 = \frac{1}{2 \times \pi \times R_2 \times 0.75 \times F_{LC}}$$

3. Set the pole at the half the switching frequency:

$$F_p = 0.5 \times F_{sw}$$

Calculate the C_1 by the equation:

$$C_1 = \frac{C_2}{\pi \times R_2 \times C_2 \times F_{sw} - 1}$$

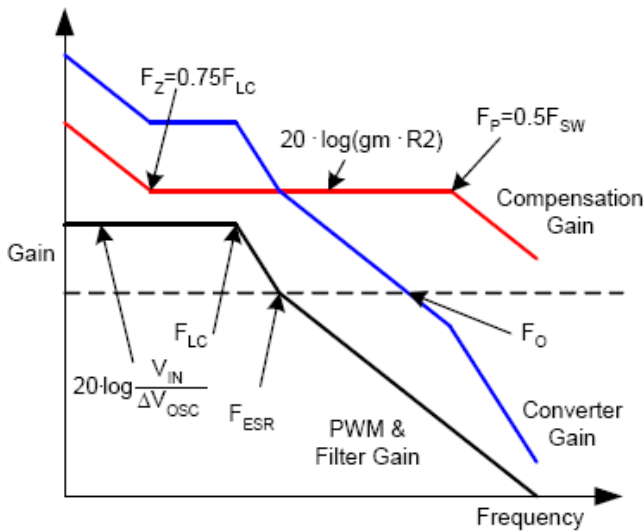

Figure 6. Converter Gain & Frequency

MOSFET Selection

The selection of the N-channel power MOSFETs is determined by the $R_{DS(ON)}$, reverse transfer capacitance (C_{RSS}), and maximum output current requirement. The losses in the MOSFETs have two components: conduction loss and transition loss. For the upper and lower MOSFET, the losses are approximately given by the following equations:

$$P_{UPPER} = I_{OUT2} (1 + TC)(R_{DS(ON)})D + (0.5)(I_{out})(V_{IN})(t_{sw})F_{SW}$$

$$P_{LOWER} = I_{OUT2} (1 + TC)(R_{DS(ON)})(1-D)$$

where I_{OUT} is the load current

TC is the temperature dependency of $R_{DS(ON)}$

F_{SW} is the switching frequency

t_{sw} is the switching interval

D is the duty cycle

Note that both MOSFETs have conduction losses while the upper MOSFET includes an additional transition loss. The switching interval, t_{sw} , is the function of the reverse transfer capacitance C_{RSS} . Figure 7 illustrates the switching waveform internal of the MOSFET.

The $(1+TC)$ term factors in the temperature dependency of the $R_{DS(ON)}$ and can be extracted from the “ $R_{DS(ON)}$ Vs Temperature” curve of the power MOSFET.

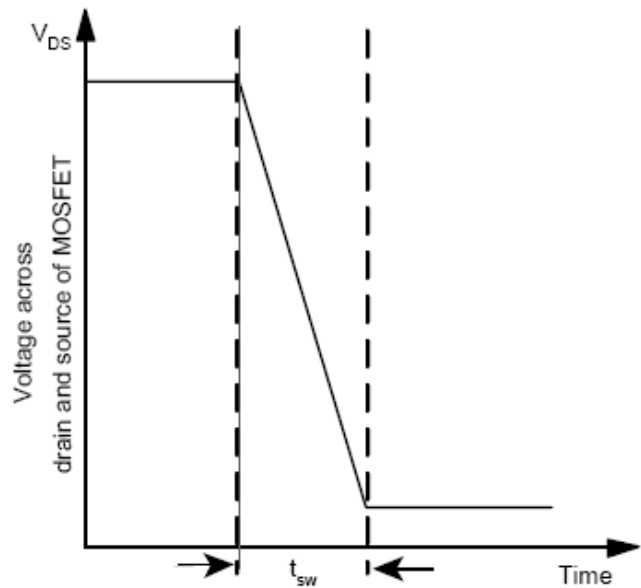

Figure 7. Switching Waveform Across MOSFET

Layout Consideration

In any high switching frequency converter, a correct layout is important to ensure proper operation of the regulator. With power devices switching at 300kHz, the resulting current transient will cause voltage spike across the interconnecting impedance and parasitic circuit elements. As an example, consider the turn-off transition of the PWM MOSFET. Before turn-off, the MOSFET is carrying the full load current. During turn-off, current stops flowing in the MOSFET and is free-wheeling by the lower MOSFET and parasitic diode. Any parasitic inductance of the circuit generates a

Application Information(Cont)

large voltage spike during the switching interval. In general, using short and wide printed circuit traces should minimize interconnecting impedances and the magnitude of voltage spike. And signal and power grounds are to be kept separate till combined using ground plane construction or single point grounding. Figure 8. illustrates the layout, with bold lines indicating high current paths; these traces must be short and wide. Components along the bold lines should be placed close together.

Below is a checklist for your layout:

- Keep the switching nodes (UGATE, LGATE, and PHASE) away from sensitive small signal nodes since these nodes are fast moving signals. Therefore, keep traces to these nodes as short as possible.
- The traces from the gate drivers to the MOSFETs (UG and LG) should be short and wide.
- Place the source of the high-side MOSFET and the drain of the low-side MOSFET as close as possible. Minimizing the impedance with wide layout plane between the two pads reduces the voltage bounce of the node.

Decoupling capacitor, compensation component, the resistor dividers, and boot capacitors should be close their pins. (For example, place the decoupling ceramic capacitor near the drain of the high-side MOSFET as close as possible. The bulk capacitors are also placed near the drain).

- The input capacitor should be near the drain of the upper MOSFET; the output capacitor should be near the loads. The input capacitor GND should be close to the output capacitor GND and the lower MOSFET GND.
- The drain of the MOSFETs (V_{IN} and PHASE nodes) should be a large plane for heat sinking.
- The R_{OCSET} resistance should be placed near the IC as close as possible.

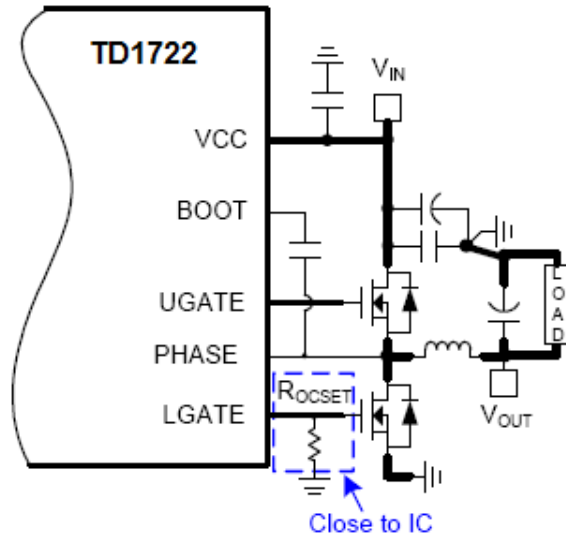
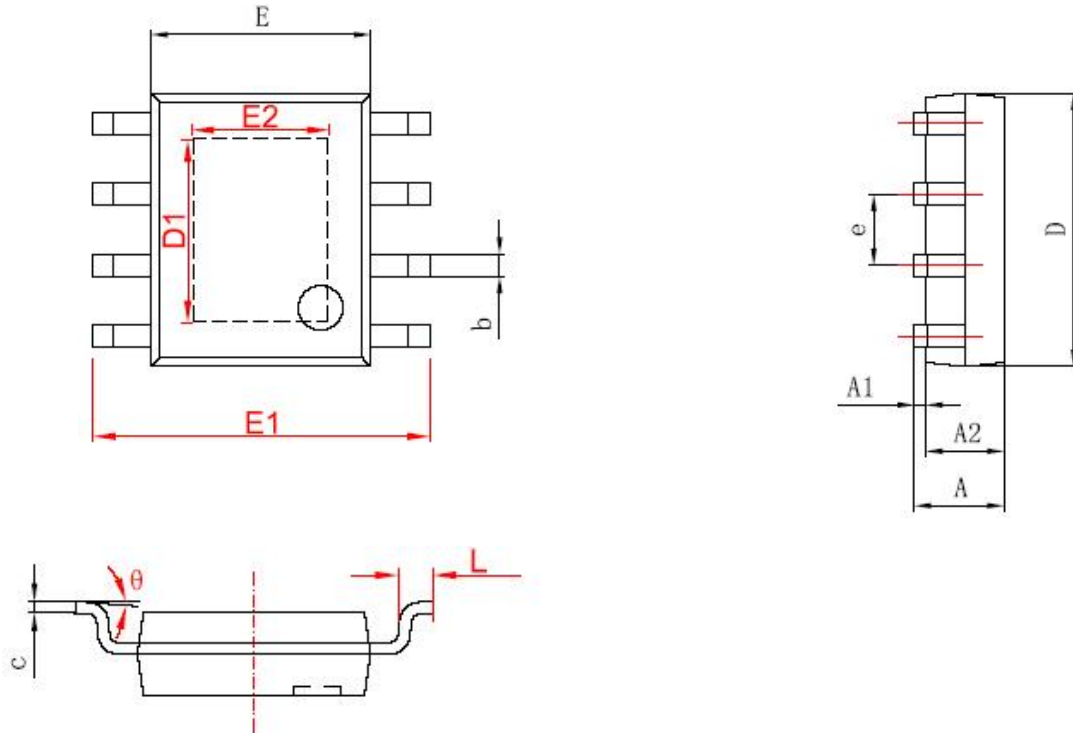

Figure 8. Layout Guidelines

Package Information

SOP8-PP Package Outline Dimensions



	Dimensions In Millimeters		Dimensions In Inches	
	Min	Max	Min	Max
A	1.350	1.750	0.053	0.069
A1	0.050	0.150	0.004	0.010
A2	1.350	1.550	0.053	0.061
b	0.330	0.510	0.013	0.020
c	0.170	0.250	0.006	0.010
D	4.700	5.100	0.185	0.200
D1	3.202	3.402	0.126	0.134
E	3.800	4.000	0.150	0.157
E1	5.800	6.200	0.228	0.244
E2	2.313	2.513	0.091	0.099
e	1.270 (BSC)		0.050 (BSC)	
L	0.400	1.270	0.016	0.050
θ	0°	8°	0°	8°

Package Information

TDFN3x3-10

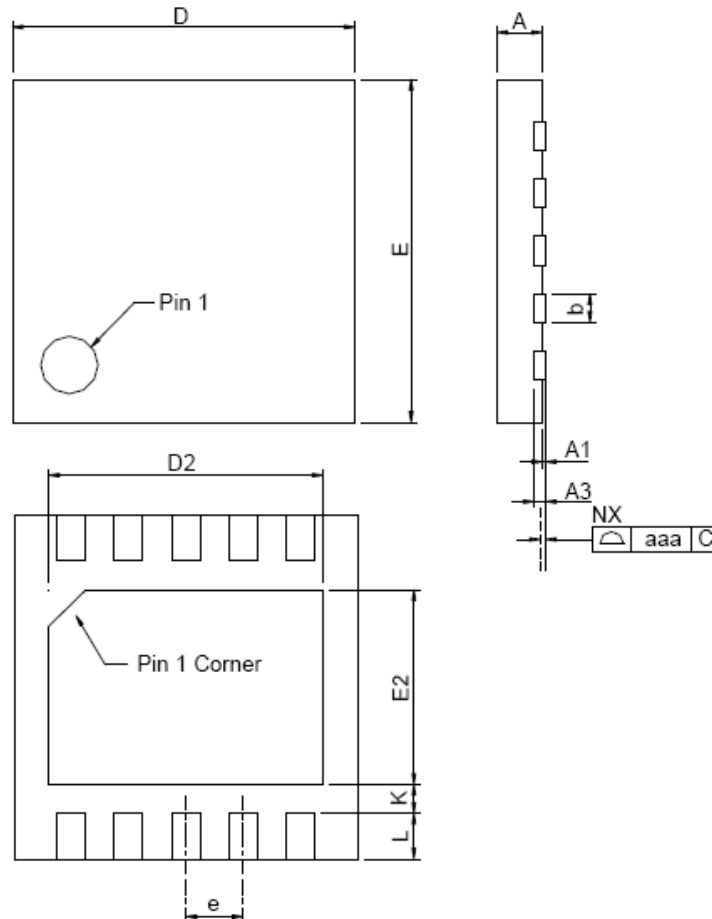

SYMBOL	TDFN3x3-10			
	MILLIMETERS		INCHES	
	MIN.	MAX.	MIN.	MAX.
A	0.70	0.80	0.028	0.031
A1	0.00	0.05	0.000	0.002
A3	0.20 REF		0.008 REF	
b	0.18	0.30	0.007	0.012
D	2.90	3.10	0.114	0.122
D2	2.20	2.70	0.087	0.106
E	2.90	3.10	0.114	0.122
E2	1.40	1.75	0.055	0.069
e	0.50 BSC		0.016 BSC	
L	0.30	0.50	0.012	0.020
K	0.20		0.008	
aaa	0.08		0.003	

Design Notes